



2024 SA SAILING YOUTH NATIONALS

Approved 29 November 2024

Dates: 15 December to 19 December 2024

Venue: East London Yacht Club, Wriggleswade Dam, Stutterheim

Organising Authority: SA Sailing in conjunction with East London Yacht Club

SAILING INSTRUCTIONS

1 COMMUNICATIONS WITH COMPETITORS

- 1.1 Notices to competitors will be posted on the Official Notice Board located at the clubhouse.
- 1.2 Contact person: Liana van Lill, Cell 066 536 7237, Email office@ELYC.co.za
- 1.3 While racing, except in an emergency, a boat shall not make voice or data transmissions and shall not receive voice or data communication that is not available to all boats.

2 CHANGES TO SAILING INSTRUCTIONS

Any change to the sailing instructions will be posted no later than 90 minutes before the first scheduled start on the day it will take effect, except that any change to the schedule of races will be posted by 19h00 on the day before it will take effect.

3 CODE OF CONDUCT

Competitors and support persons shall comply with reasonable requests from race officials.

4 SIGNALS MADE ASHORE

- 4.1 Signals made ashore will be displayed from the jetty in front of the clubhouse.
- 4.2 When flag AP is displayed ashore, "1 minute" is replaced with "not less than 30 minutes" in Race Signals AP.
- 4.3 When Flag "D" is flown, the start will not be within 30 minutes of Flag "D" being dropped.

5 CLASS FLAGS

Class flags and the order of starting will be posted before the close of registration.

6 RACING AREA

Racing area A and Racing area B will be displayed on the notice board at the clubhouse from the start of registration.

7 COURSES

The course diagrams will be posted on the noticeboard at the clubhouse by 18H00 on 14 December.

8 MARKS

A description of all marks will be posted on the notice board by 18h00 on 14 December.

9 THE START

9.1 The starting line will be between a staff displaying an orange flag on the signal vessel at the starboard end and the course side of the port-end starting mark.

9.2 Boats whose warning signal has not been made shall avoid the starting area during the starting sequence for other races.

9.3 A boat that does not start within 4 minutes after her starting signal will be scored Did Not Start without a hearing. This changes RRS 35, A4 and A5.1.

10 CHANGE OF THE NEXT LEG OF THE COURSE

To change the next leg of the course, the race committee will move the original mark or the finishing line to a new position.

11 THE FINISH

The finishing line will be between a staff displaying a blue flag on the race committee vessel at the starboard end and the course side of the port-end finishing mark.

12 SHORTENING COURSE

In addition to the provisions of RRS 32, the race committee may also signal a shortened course by displaying flag F with repeated sounds from a boat near a rounding mark. On this signal, boats shall round the mark, as required to sail the course, and thereafter proceed directly to the finish line. This signal shall be made before the first boat reaches the mark, and shall continue to be made until all boats still racing have rounded this mark. This changes RRS 32.

13 PENALTY SYSTEM

13.1 RRS Appendix P, rules P1 -P4 will apply.

13.2 RRS P2.3 does not apply and RRS P2.2 is changed so that it applies to any penalty after the first one.

14 TIME LIMITS

14.1 Boats failing to finish within 20 minutes after the first boat in her class sails the course and finishes, and not subsequently retiring, being penalised or given redress, will be scored Time Limit Expired (TLE) without a hearing. A boat scored TLE shall be scored points for the finishing place one more than the points scored by the last boat that finished within this time limit. This changes RRS 35, A5.1, A5.2 and A10.

14.2 In the open class Sailing instruction 14.1 above is applicable from when the first boat from the open class finishes.

15 HEARING REQUESTS

15.1 The protest time limit is 60 minutes after the last boat on a course finishes the last race of the day or the race committee signals no more racing today, whichever is the later. The time will be posted on the official notice board.

15.2 Hearing request forms are available from the race office and once completed, must be returned to the race office. The time of receipt of the form will be recorded on the form by the race office.

15.3 Notices will be posted no later than 30 minutes after the protest time limit to inform competitors of hearings in which they are parties or named as witnesses. Hearings will be held in an allocated room, located at the club house, beginning at the time posted.

15.4 A list of boats that have been penalised for breaking RRS 42 under Appendix P will be posted.

16 SCORING

16.1 4 races are required to be completed to constitute a series.

16.2 (a) When fewer than 5 races have been completed, a boat's series score will be the total of her race scores.

(b) When from 5 to 9 races have been completed, a boat's series score will be the total her race scores excluding her worst score.

(c) When 10 or more races have been completed, a boat's series score will be the total of her race scores excluding her two worst scores.

17 SAFETY REGULATIONS

17.1 All competitors shall wear a personal flotation device capable of supporting a 5 kg steel weight at all times while afloat, except briefly while changing or adjusting clothing or personal equipment.

17.2 A boat that retires from a race shall notify the race committee at the first reasonable opportunity.

18 REPLACEMENT OF CREW OR EQUIPMENT

18.1 Substitution of competitors is not allowed without prior written approval of the race committee.

18.2 Substitution of damaged or lost equipment will not be allowed unless approved by the race committee. Requests for substitution shall be made to the committee at the first reasonable opportunity, which may be after the race.

19 EQUIPMENT AND MEASUREMENT CHECKS

19.1 A boat or equipment may be inspected at any time for compliance with the class rules, notice of race or sailing instructions.

19.2 When instructed by a race official on the water, a boat shall proceed to a designated area for inspection.

20 SUPPORT PERSON VESSEL

Support person vessels shall stay outside of the course and at least 100m from boats racing.

21 TRASH DISPOSAL

Trash may be placed aboard official or support person vessels.

22 ADDITIONAL IDENTIFICATION

22.1 While racing, boats shall display their sail number as prescribed by their class measurement standard as the sole identification.

Course 1:

Start

1 Lap = 1p – 2p

Finish

Note: Number of laps to be indicated on the back of the start boat.

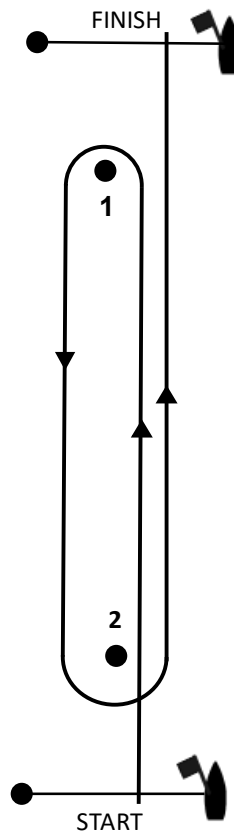

Course 2:

Start

1p – 2p – 3p

1p – 3p

Finish

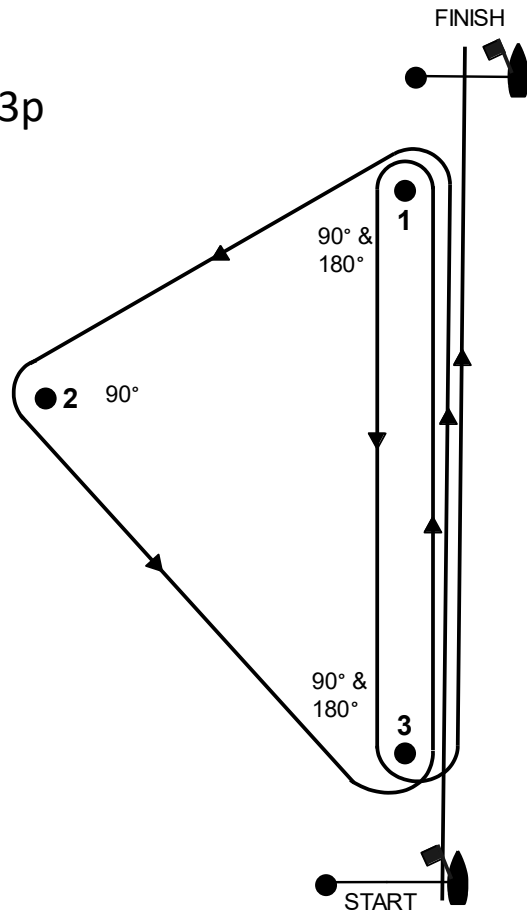

Course 3:

Start

1p – 2p – 3p

1p – 3p

1p – 2p – 3p

Finish

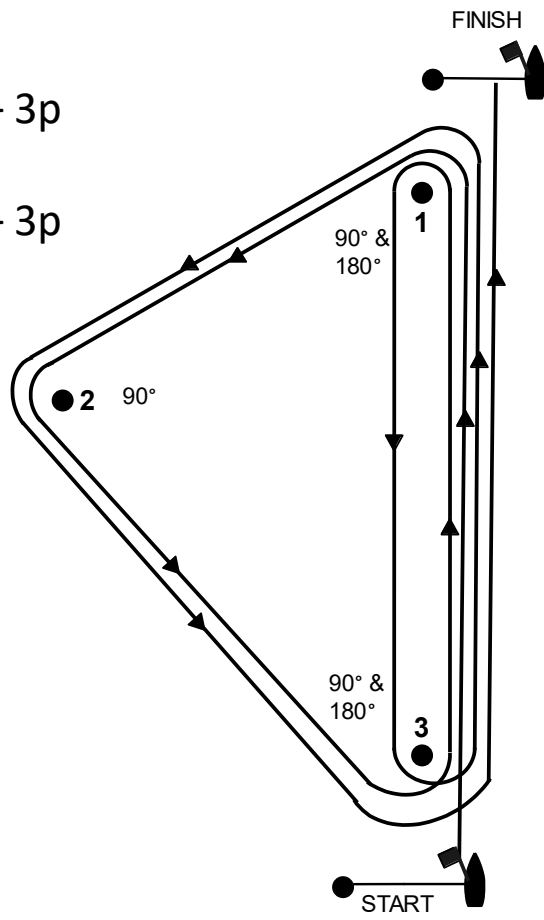

Course 4:

Start

1p – 2p – 3s or 3p

Finish

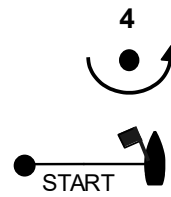
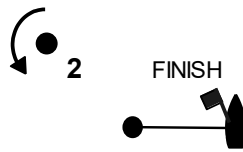

Course 5:

Start

1p – 2p – 4p

1p – 4p

1p – 2p – 3s or 3p

Finish

